

High Productivity Cooking Electric Boiling Pan, 150lt Hygienic Profile, Backsplash with Stirrer & Tap

ITEM # _____

MODEL # _____

NAME # _____

SIS # _____

AIA # _____

586395 (PBON15RLEM)

 Electric Boiling Pan 150lt (h),
 round with mixing tap and
 prearranged for stirrer,
 GuideYou panel, backsplash

Short Form Specification

Item No.

AISI 304 stainless steel construction. Vessel with rounded edges in AISI 316 stainless steel. Insulated and counterbalanced lid. Water mixing unit included. Unit to include food tap. Stirring rotation speed 21rpm. Stirrer drive shaft included, stirrer blades to be ordered separately. Food is uniformly heated via the base and the side walls of the pan by an indirect heating system using integrally generated saturated steam at a maximum temperature of 125°C in a jacket with an automatic deaeration system. Safety valve avoids overpressure of the steam in the jacket. Safety thermostat protects against low water level in the double jacket. TOUCH control panel. SOFT function. Possibility to store recipes in single or multiphase cooking process, with different temperature settings. Built in temperature sensors for precise control of cooking process. IPX6 water resistant. Configuration: Standing against a wall. Installation options (not included): floor mounted on 200mm high feet or a plinth which can be either steel or masonry construction.

Main Features

- Kettle is suitable to boil, steam, poach, braise or simmer all kinds of produce.
- Large capacity food tap enables safe and effortless discharging of contents.
- Kettle is jacketed up to 159 mm from upper rim.
- Isolated upper well rim avoids risk of harm for the user.
- Safety valve avoids overpressure of the steam in the jacket.
- Discharge tap is very easy to disassemble and clean.
- Ergonomic vessel dimensions, with a large diameter and shallow depth facilitates stirring and gentle food handling.
- IPX6 water resistant.
- Built in temperature sensor to precisely control the cooking process.
- USB connection to easily update the software, upload/download recipes and download HACCP data.
- Max pressure of inner jacket at 1.7 bar; minimum working pressure at 1 bar. Allows temperature control between 50 and 110°C.

Construction

- Cooking vessel in 1.4435 (AISI 316L) stainless steel. Double-jacket in 1.4404 (AISI 316L) stainless steel designed to operate at a pressure of 1.5 bar.
- External panelling and internal frame made of 1.4301 (AISI 304) stainless steel.
- Double-lined insulated lid in 1.4301 (AISI 304) stainless steel mounted on the cross beam of the unit, counterbalanced by a hinge that remains open in all positions.
- Safety thermostat protects against low water level in the double jacket.
- 2" diameter discharge tap for rapid emptying of the well.
- Minimised presence of narrow gaps for easier cleaning of the sides to meet the highest hygiene standards.
- Integrated water mixing tap to make water filling and pan cleaning operations easier.
- Front-mounted inclined led "TOUCH" control panel with recessed deep drawn casing, features self-explanatory display functions which guide operator throughout the cooking process: simultaneous display of actual and set temperature as well as set cooking time and remaining cooking time; real time clock; "SOFT" control for gentle heating up for delicate food; 9 power simmering levels from gentle to heavy boiling; timer for deferred start; error display for quick trouble-shooting.

APPROVAL: _____

- Possibility to store recipes in single or multiphase cooking process, with different temperature settings.
- Can be prearranged for energy optimisation or external surveillance systems (optional).
- 98% recyclable by weight; packaging material free of toxic substances.
- Factory fitted: installed directly by the factory.
- In case of the installation against the wall on the right side of the unit, it is mandatory to use mixing tap with short swivelling arm code 913572 (SPECIAL EXECUTION REQUEST).
- Stirrer with rotation speed of 21 RPMs.
- GuideYou Panel - activated by the user via settings - to easily follow the multiphase recipes, granting a proper and controlled cooking and a better appliance optimization.
 The system will provide maintenance reminders, in line with ESSENTIA program, helping the user to properly take care of the product, avoiding downtimes.
- Highly-visible and bright led TOUCH control panel features user-friendly icons and intuitive self-explanatory command options. Display visualizes:
 - Actual and set temperature
 - Set and remaining cooking time
 - Pre-heating phase (if activated)
 - GuideYou Panel (if activated)
 - Deferred start
 - Soft Function to reach the target temperature smoothly
 - 9 Power Control levels from simmering to fierce boiling
 - Pressure mode (in pressure models)
 - Stirrer ON/OFF settings (in round boiling models)
 - Error codes for quick trouble-shooting
 - Maintenance reminders

Sustainability

- High-quality thermal insulation of the pan saves energy and keeps operating ambient temperature low.

User Interface & Data Management

- Connectivity ready for real time access to connected appliances from remote and data monitoring (requires optional accessory - contact the Company for more details).

Included Accessories

- 1 of Emergency stop button - factory fitted PNC 912784

Optional Accessories

- Grid stirrer for 150lt boiling pans PNC 910064
- Grid stirrer and scraper for 150lt boiling pans PNC 910094
- Food tap strainer for stationary round boiling pans PNC 910161
- Food tap strainer rod for stationary round boiling pans PNC 910162

- Manometer kit for stationary boiling pans - long - factory fitted PNC 912120
- Power Socket, CEE16, built-in, 16A/400V, IP67, red-white - factory fitted PNC 912468
- Power Socket, CEE32, built-in, 32A/400V, IP67, red-white - factory fitted PNC 912469
- Power Socket, SCHUKO, built-in, 16A/230V, IP68, blue-white - factory fitted PNC 912470
- Power Socket, TYP23, built-in, 16A/230V, IP55, black - factory fitted PNC 912471
- Power Socket, TYP25, built-in, 16A/400V, IP55, black - factory fitted PNC 912472
- Power Socket, SCHUKO, built-in, 16A/230V, IP55, black - factory fitted PNC 912473
- Power Socket, CEE16, built-in, 16A/230V, IP67, blue-white - factory fitted PNC 912474
- Power Socket, TYP23, built-in, 16A/230V, IP54, blue - factory fitted PNC 912475
- Power Socket, SCHUKO, built-in, 16A/230V, IP54, blue - factory fitted PNC 912476
- Power Socket, TYP25, built-in, 16A/400V, IP54, red-white - factory fitted PNC 912477
- Connecting rail kit for appliances with backsplash, 900mm PNC 912499
- Measuring rod for 150lt round stationary boiling pans PNC 912725
- Set of 4 feet for stationary units (height 200mm) - factory fitted PNC 912732
- Automatic water filling (cold) for stationary units (width 700-1400mm): rectangular pressure boiling and braising pans - factory fitted PNC 912734
- Automatic water filling (hot and cold) for stationary units (width 700-1000mm): rectangular pressure boiling and braising pans - factory fitted PNC 912736
- Kit energy optimization and potential free contact - factory fitted PNC 912737
- Mainswitch 60A, 6mm² - factory fitted PNC 912740
- Integrated HACCP kit - factory fitted PNC 912781
- External touch control device for stationary units - factory fitted PNC 912783
- Wall mounting kit for stationary units - factory fitted PNC 912786
- Connecting rail kit for appliances with backsplash: modular 90 (on the left) to ProThermetic tilting (on the right), ProThermetic stationary (on the left) to ProThermetic tilting (on the right) PNC 912981

- Connecting rail kit for appliances with backsplash: modular 90 (on the right) to ProThermetic tilting (on the left), ProThermetic stationary (on the right) to ProThermetic tilting (on the left) PNC 912982
- Rear closing kit for stationary units with backsplash - factory fitted PNC 912990
- Stainless steel plinth for stationary units - against the wall - factory fitted PNC 913308
- Kit endrail and side panels, flush-fitting, for installation with backsplash, left - factory fitted PNC 913382
- Kit endrail and side panels, flush-fitting, for installation with backsplash, right - factory fitted PNC 913383
- Kit endrail and side panel (12.5mm), for installation with backsplash, left - factory fitted PNC 913406
- Kit endrail and side panel (12.5mm), for installation with backsplash, right - factory fitted PNC 913407
- Drain standpipe for boiling pans (PBON010/15) PNC 913427
- Mixing tap with two knobs, 327mm height, 450mm swivelling depth for PXXN- KWC (in case of installation against the wall on the right side of the boiling pan, it is mandatory to use mixing tap with short swivelling arm code 913572) - factory fitted PNC 913564
- Mixing tap with two knobs and a short swivel arm for the installation against the wall on the right side of the unit for PXXN - factory fitted PNC 913572
- Connectivity kit for ProThermetic Boiling and Braising Pans ECAP - factory fitted PNC 913577

High Productivity Cooking Electric Boiling Pan, 150lt Hygienic Profile, Backsplash with Stirrer & Tap

Front

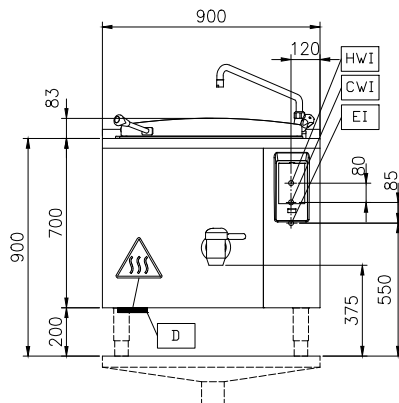

Side

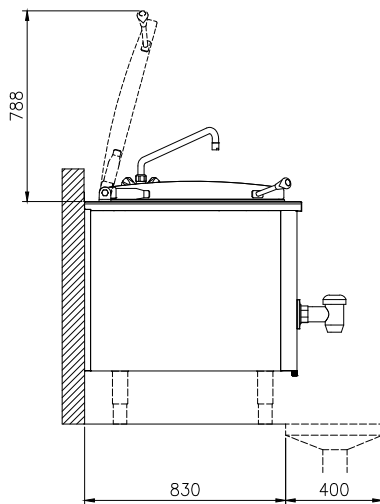

CWI = Cold Water inlet 1 (cleaning)
 EI = Electrical inlet (power)
 HWI = Hot water inlet

Top

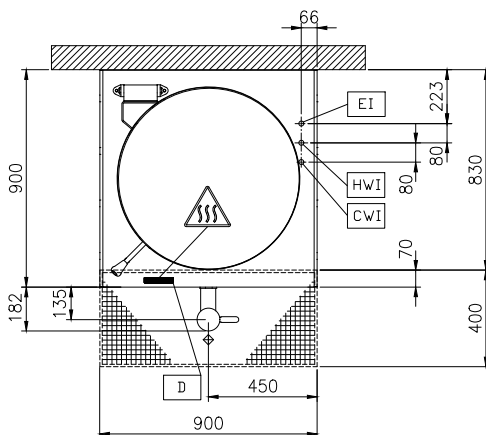

Electric

Supply voltage: 400 V/3N ph/50/60 Hz
Total Watts: 24.4 kW

Installation:

Type of installation:

FS on concrete base; FS on feet; On base; Standing against wall; Wall mounted (with wall-kit)

Key Information:

Working Temperature MIN: 50 °C
Working Temperature MAX: 110 °C
Vessel (round) diameter: 710 mm
Vessel (round) depth: 465 mm
External dimensions, Width: 900 mm
External dimensions, Depth: 900 mm
External dimensions, Height: 700 mm
Net weight: 150 kg
Configuration: Round; Fixed; Pre-arranged for stirrer; With splashback
Net vessel useful capacity: 150 lt
Double jacketed lid: ✓
Heating type: Indirect

High Productivity Cooking
 Electric Boiling Pan, 150lt Hygienic Profile, Backsplash with Stirrer & Tap

The company reserves the right to make modifications to the products without prior notice. All information correct at time of printing.